

General characteristics

- Magnetic sensor for contactless linear and angular reading.
- Small overall dimensions allow installation in narrow spaces.
- Resolutions up to 0.5 μm programmable through serial interface.
- Easy and fast mounting with wide alignment tolerances.
- 8-wire shielded cable as standard with low friction coefficient and oil-resistant.
- Electrical protection against inversion of power supply polarity and short circuits.
- Protection class IP67.

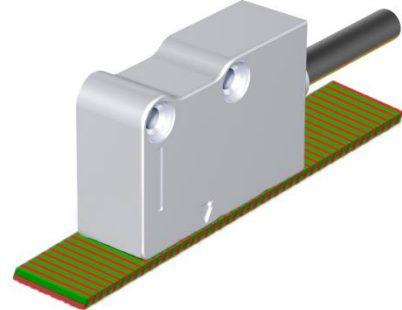

Technical characteristics

Pole pitch	1+1 mm			
Reference indexes	C = constant step (every 1 mm)			
Resolution (μm)	10	5	1	0.5
Accuracy (μm) ¹⁾	± 6			
Max. traversing speed ²⁾	0.6 m/s (resolution 0.5 μm) 6 m/s (resolution 10 μm)			
Max. frequency	300 kHz (up to 500 kHz on request)			
Repeatability	± 1 increment			
A, B and I ₀ output signals	Line Driver / Push-Pull			
Vibration resistance (EN 60068-2-6)	300 m/s ² [55 ... 2,000 Hz]			
Shock resistance (EN 60068-2-27)	1.000 m/s ² (11 ms)			
Protection class (EN 60529)	IP67			
Operating temperature	0 °C ... 50 °C			
Storage temperature	-20 °C ... 80 °C			
Relative humidity	100%			
Power supply	5 ... 28 VDC $\pm 5\%$			
Current consumption without load	60 mA _{MAX}			
Current consumption with load	140 mA _{MAX} (with 5 V and R = 120 Ω) 90 mA _{MAX} (with 28 V and R = 1.2 k Ω)			
Electrical connections	see related table			
Electrical protections	inversion of polarity and short circuits			
Weight	40 g			

- ¹⁾ To obtain the declared accuracy values, it is necessary to respect the alignment tolerances prescribed by the Manufacturer. Better accuracy can be obtained by reducing the gap between the sensor and the magnetic scale.
- ²⁾ The indicated speeds are referred to a maximum frequency of 300 kHz.

Datasheet

Mechanical characteristics

- Magnetic sensor with die-cast body.
- Possibility to fix the magnetic sensor with M4 screws or with through M3 screws.
- Wide alignment tolerances.

Electrical characteristics

- Very flexible power cable.
- Reading through positioning sensor based on magneto resistance, with AMR effect (Magnetic Anisotropy).
- High signal stability.
- Electrical protection against inversion of power supply polarity and short circuits on output port.
- For applications where the maximum speed exceeds 1 m/s, it is necessary to use a PUR cable suitable for continuous movements.

Wiring and pin assignment (assignment according to DIN 47100)

8-wire connecting cable

Incremental magnetic sensor IMS1 is supplied with an 8-wire shielded cable, $\varnothing = 6.1$ mm, PVC external sheath, with low friction coefficient and oil-resistant.

Conductors section:

- power supply: 0.35 mm²
- signals: 0.14 mm²

PUR cable or cable with reduced section are available on request.



**PUR cable is suitable for continuous movements.
The cable's bending radius should not be lower than 60 mm.**

Pin diagram **connector M12 plug**, 8-pin, A-coded, view plug side, connected to the connecting cable of the magnetic sensor.

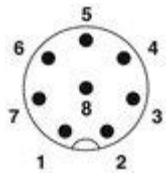

Line Driver	Push-Pull	PIN	Conductor colour
I ₀	I ₀	1	brown
$\overline{I_0}$	NC	2	yellow
B	B	3	white
\overline{B}	NC	4	light-blue
\overline{A}	NC	5	orange
A	A	6	green
0V	0V	7	blue
+V	+V	8	red
SCH	SCH		Shield

NC = not connected

Datasheet

8-wire extension cable

Pin diagram connector M12 plug, 8-pin, A-coded, view plug side, connected to an extension cable (e.g. 0,3 m, 5 m, or 30 m).

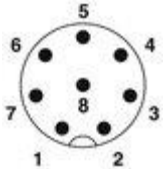

Signal	PIN	Conductor colour
I_0	1	white
$\overline{I_0}$	2	brown
B	3	green
\overline{B}	4	yellow
\overline{A}	5	pink
A	6	grey
0V	7	blue
+V	8	red
SCH		Shield

Pin diagram connector M12 socket, 8-pin, A-coded, view socket side, connected to an extension cable (e.g. 0,3 m, 5 m, or 30 m).

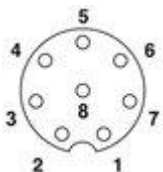

Signal	PIN	Conductor colour
I_0	1	white
$\overline{I_0}$	2	brown
B	3	green
\overline{B}	4	yellow
\overline{A}	5	pink
A	6	grey
0V	7	blue
+V	8	red
SCH		Shield

Datasheet

Output signals

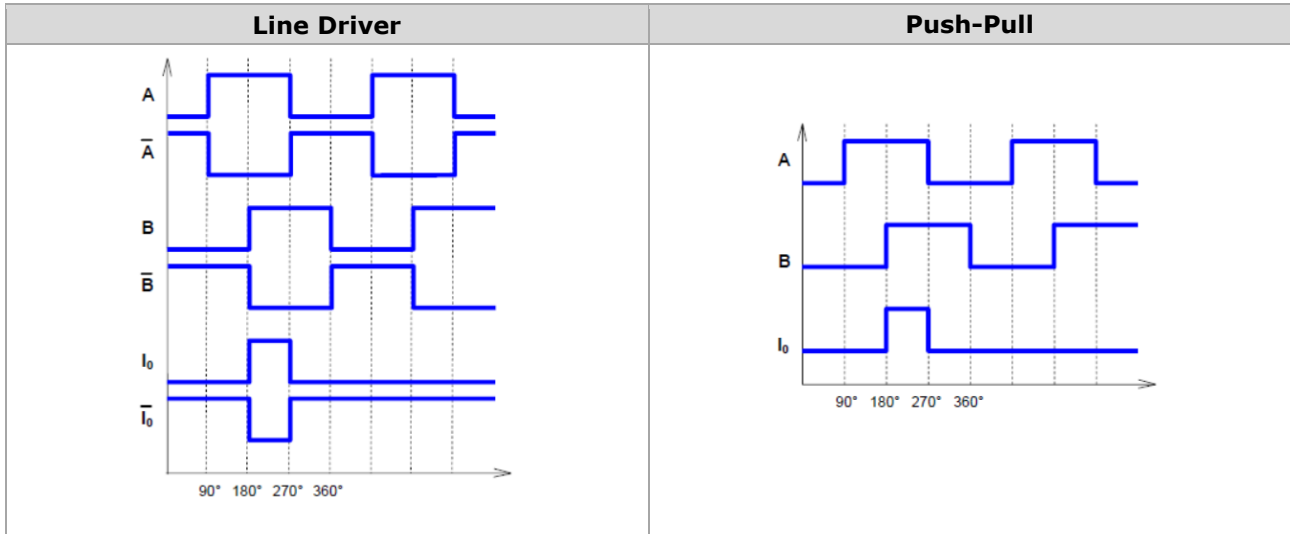

Dimensions

IMS1 + PM100

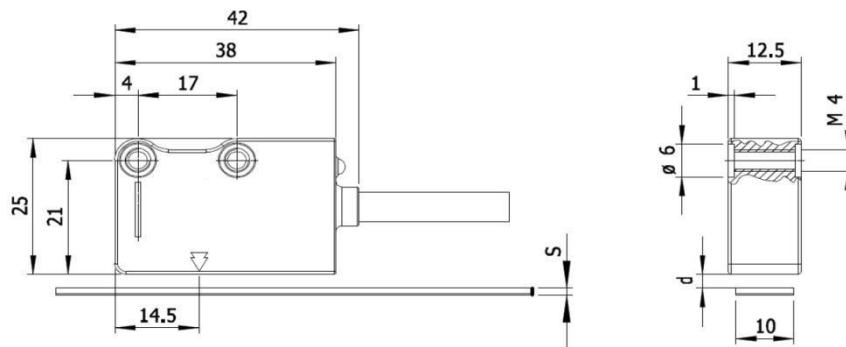

All dimensions in mm

Value in mm	PM100	PM100 + DB01	PM100 + PS1
s	1.3	1.6	2.1
d IMS1	0.2 ... 1.4	Not applicable	Not applicable

s = thickness magnetic scale

d = distance to be observed between the sensor and the surface of the magnetic scale (or eventual cover tape/ support)

Datasheet

Alignment tolerances

IMS1 + PM100

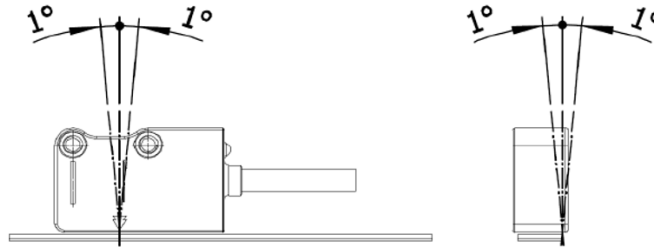

IMS1 + PM100

a (mm) = alignment tolerance

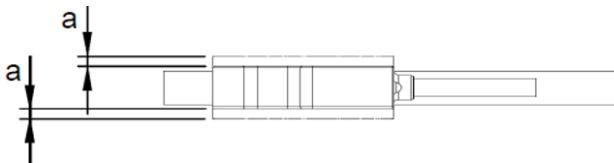

$$a = 3_{\text{MAX}} \text{ IMS1-}_{-}\text{C}$$

Reference indexes:

C = constant step (every 1 mm)

NOTICE

- Avoid the direct contact with magnetized objects or tools that could damage the surface.
- **Do not touch** the contacts of the cable's connector to avoid electrostatic discharges (ESD) on the device.

Datasheet

Ordering example

Type IMS1 - 10 - C - 528V - L - M02/N - SC

Pole pitch

1 = 1+1 mm

Resolution [μm]

10 / 5 / 1 / 0.5

Reference index

C = constant step (every 5 mm) ¹⁾

Power supply

528V = 5 VDC ... 28 VDC

5285 = 5 VDC ... 28 VDC with 5 V output

Output signals

L = Line Driver

Y = Push-Pull

Cable ^{1) 2)}

M01/N = 1 m

M02/N = 2 m

M03/N = 3 m

Connection

SC = without connector, open cable end

Cxx = progressive (e.g. C08 = connector M12 plug, 8-pin)



Cable

- 1) Different cable lengths are available. The sensor is provided with a 2 m cable as standard. Longer lengths are available with the following application limits:
 $L_{\text{max}} = 10 \text{ m}$ sensor cable
 $L_{\text{max}} = 100 \text{ m}$ sensor cable (2 m) + cable extension
Cable extensions need to have a 0.5 mm^2 section for power supply conductors.
- 2) For applications where the maximum speed exceeds 1 m/s, it is necessary to use a PUR cable suitable for continuous movements.



Accessories

Please order the magnetic scale, the corresponding cover tape, and the extension cable separately. For ordering information, please refer to the corresponding data sheet. You can configure the enclosure according to your requirements from the technical information and enter it into the ordering code. Variants that cannot be configured from the ordering example are available on request as a special version.

Without prior notice, the products may be subject to modifications that the Manufacturer reserves to introduce as deemed necessary for their improvement. Mistakes excepted.