

# Datasheet

Position indicator with continuous hollow shaft

## Features at a glance

- 3 digit indicator to adjust and directly read a motion (or an angle)
- Inclined view at 45° for horizontal shafts and for vertical shafts
- excellent readability given by the means of magnifying window
- particularly suitable for little adjustments in small spaces



On request:

- Special ratios and measures in Inch
- Distance of anti-rotation lock-pin 22 mm
- Colours, glossy finish: orange RAL 2004, black RAL 9005, grey RAL 7004
- Combinable tools: flanged gearbox, RINV-OP62, Worm gearbox RD26
- Attachments (see page 5)

## Mechanical Data

|   |   |
|---|---|
| Dimension<br>Hollows Shaft<br>Torque Support      | Ø 8; Ø 10; Ø 12 H7 mm<br>Ø 18 mm, Ø 22 mm (on request)                                      |
| Material<br>Housing<br>Window<br>Hollow Shaft     | technopolymer, self-extinguishing<br>magnifying lens<br>stainless steel                     |
| Measuring Range                                   | < 999   |
| Digit Height                                      | 6 mm  |
| Digits<br>1 red digits<br>2 red or 3 black digits | decimals (standard)<br>hundredths (on request)  |
| Operating Temperature                             | < 80°C  |
| Protection class                                  | IP64  |
| Options<br>on request<br>Color (glossy finish)    | measure in Inch, special ratios<br>orange -> RAL2004<br>black -> RAL9005<br>grey -> RAL7004 |

# Datasheet

## Assembly

- Place the device over the hollow shaft and ensure that the torque support is inserted into the existing bore. Set the display value to the starting position (zero) and secure the grub screw.

## Mounting Position

**View A - horizontal**



**View B - vertical**



**Counting Direction**



**SX**  
left ascending

**DX**  
right ascending

**Display**



Standard



Optional (2RR)



Optional (3RN)

## Dimensions

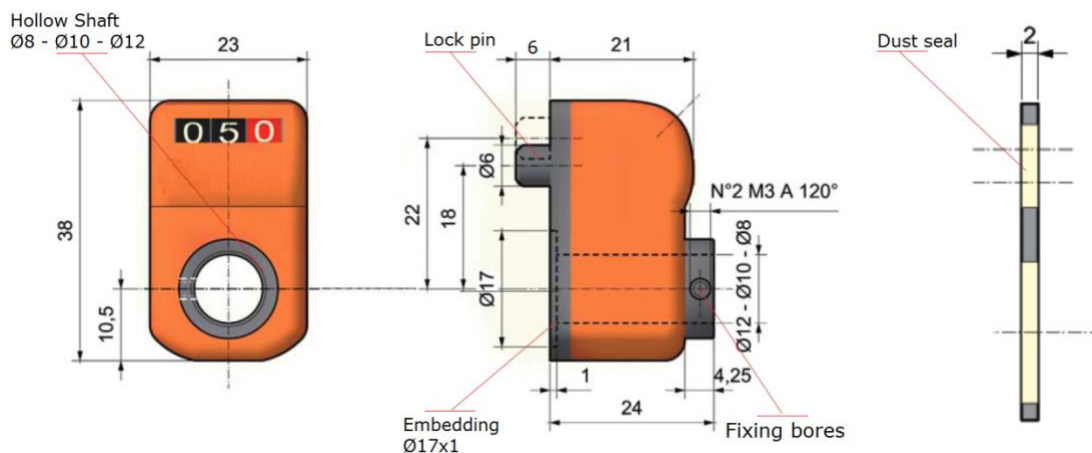

Introduce the indicator through the hollow shaft and set the lock pin into the  $\phi 6$  arranged hole. Set the instrument on the inner (zero) value and block with the fixing screw.

# Datasheet

## Pitch

| pitch<br>[mm] | measure after 1 revolution<br>[mm] | maximum shaft speed<br>[U/min <sup>-1</sup> ] |
|---------------|------------------------------------|---|
| 0,5           | <b>005</b>                         | 1000  |
| 0,50          | <b>050</b>                         | 120   |
| 0,7/5         | <b>007 5</b>                       | 600   |
| 1,0           | <b>010</b>                         | 800   |
| 1,00          | <b>100</b>                         | 60  |
| 1,2/5         | <b>012 5</b>                       | 600   |
| 1,5           | <b>015</b>                         | 500   |
| 1,7/5         | <b>017 5</b>                       | 400   |
| 2,0           | <b>020</b>                         | 350   |
| 2,5           | <b>025</b>                         | 300   |
| 3,0           | <b>030</b>                         | 250   |
| 4,0           | <b>040</b>                         | 200   |
| 5,0           | <b>050</b>                         | 150   |
| 6,0           | <b>060</b>                         | 120   |
| 8,0           | <b>080</b>                         | 75  |
| 10,0          | <b>100</b>                         | 60  |

# Datasheet

## Ordering Example

**Type** OP2 - A - 2,5 - DX - 10 - R - I18

### View

A = horizontal  
B = vertical

### Pitch

Measure after one revolution  
see table

### Counting Direction

DX = clockwise ⌚  
SX = anti-clockwise ⌚

### Hollow Shaft Diameter [mm]

8 = Ø8 H7  
10 = Ø10 H7  
12 = Ø12 H7  
Further diameters possible with reducing bushes

### Color

R = orange; RAL2004  
G = black; RAL9005  
GR = grey; RAL7004

### Axis Distance











I18 = 18 mm (standard)  
I22 = 22 mm (on request)



Other versions that cannot be generated from the order code may be available as special versions on request.

# Datasheet

## Accessories

|   |   |  |   |
|---|---|--|---|
| <p>Handwheels</p>                                    | <p>Hand crank with reversible handles</p>                                  | <p>Rotary knobs</p>  | <p>Reducing sleeves</p>  |
| <p>Reducing sleeves shaft clamping flanges</p>      | <p>Shaft clamping flanges</p>   | <p>Flanges</p>       | <p>Bearing blocks</p>   |
| <p>RINV-OP62<br/>Angular gearbox with flanges</p>  | <p>RD26-FL<br/>Worm gearbox with coupling flang and extension shaft</p>  |  |   |

## System components

|   |   |   |  |
|---|---|---|--|
| <p>Mechanical/digital position indicators</p>  | <p>Electronic/digital position indicators</p>  | <p>Programmable position indicators</p>  <p>     </p> | <p>Angular gearbox</p>  |
|---|---|---|--|

Possible combinations / applications



Further information can be found on our homepage [www.willtec.de](http://www.willtec.de)

Manufacturer: **FIAMA**  
since 1913

The manufacturer reserves the right to make any changes to the products that it deems necessary to improve them without prior notice.